

林氏木业

安装示意图

产品名称 LS713P3-A

产品规格 750*260*460

安装工具



安装人员



Parts list

No.	Name	Size	QTY.
1	Upper board	233*260*41	1
2	Lower board	750*260*41	1
3	Support leg L	482*35*12	2
4	Support leg R	482*35*12	2

Hardware list

No.	Name	PIC.	QTY.
A	Screw	M6*10	8
B	Screw	M6*15	8
C	Wrench	4#	2

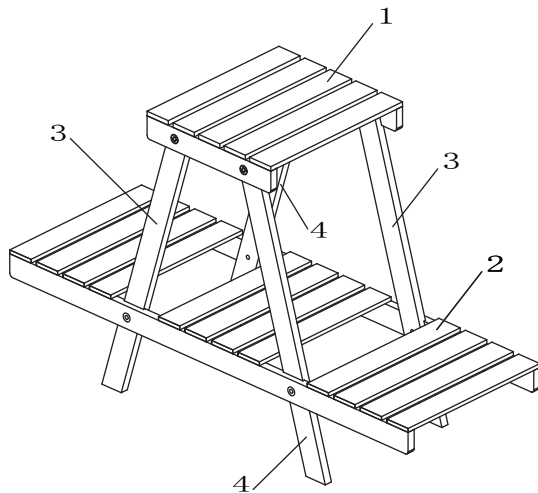

Do not put your hand into the seam during installation to avoid clamping your hand.

Reminder:
During the step, do not use force to pull away when get stuck during installation, to avoid the product damage.

Please pay attention not to tighten each hardware at once during installation.
wait for all the hardware assembly before fixing and tightening.

Step

- ① First clamp part 3/4 (left/right support leg) to part 2 (lower board), and then assemble it with hardware A/B.

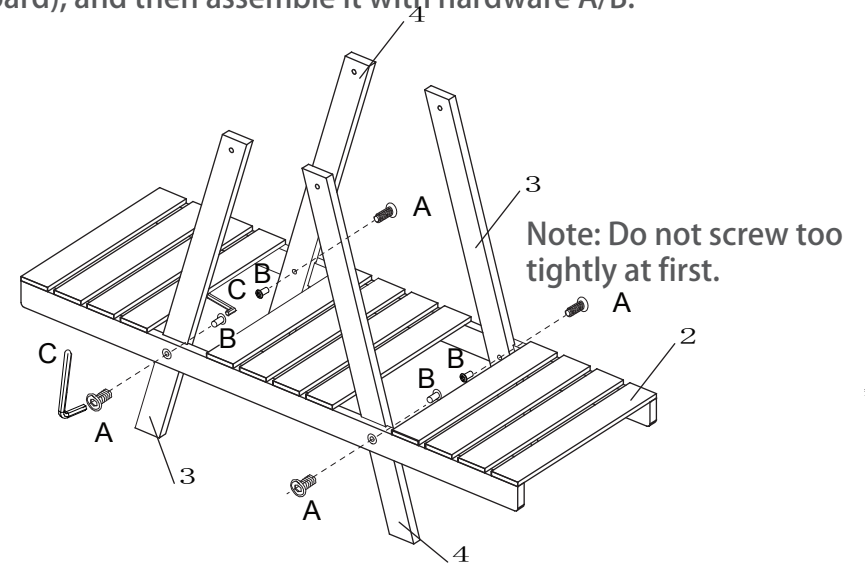

- ② First clamp part 1 (upper board) on part 3/4 (left/right support feet), then assemble it with hardware A/B. Then tighten the hardware in the previous step. Complete assembly.

