

# 林氏木业

## 安装示意图

产品名称 LS232P3-A

产品规格 455\*455\*860

安装工具



安装人员



### Parts list

No.	Name	Size	QTY
1	Plate	∅220*25	3
2	Board	224*218*25	1
3	Lower support leg	400*∅32	2
4	Upper support leg	400*∅32	1
5	Short support	180*∅32	1
6	Long support	400*∅32	1
7	Base	∅370*36	1

### Component list

No.	Name	PIC.	QTY
A	Screw	M5*50	3
B	Screw	M8*40	3
C	Foot pad		4
D	Wrench	5#	1
E	Aluminium sleeve	∅32*30	2
F	Wrench	4#	1

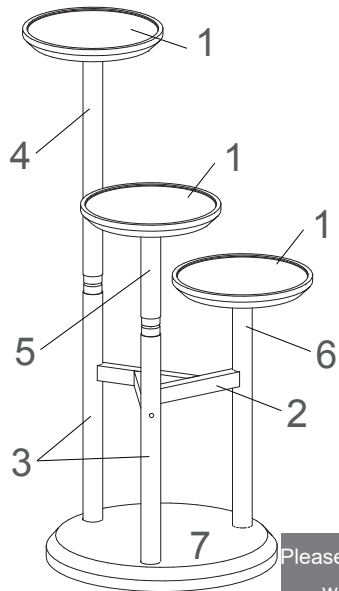

Do not put your hand into the seam during 6 9 installation to avoid clamping your hand.

Reminder:  
During the step, do not use force to pull away when get stuck during installation, to avoid the product damage.

Please pay attention not to tighten each hardware at once during installation, wait for all the hardware assembly before fixing and tightening.

## 安装步骤

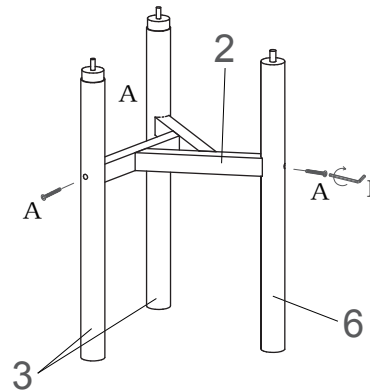

1. Connect part (3)/(6) to part (2) with the hex self-tapping screw A.

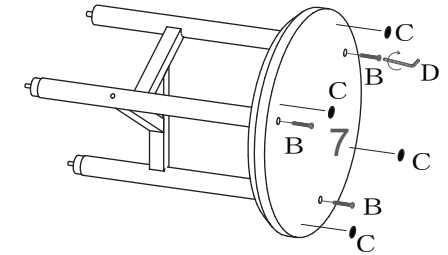

2. Connect the part (7) with the support bar with the hex self-tapping screw B, then put the foot pad on C.

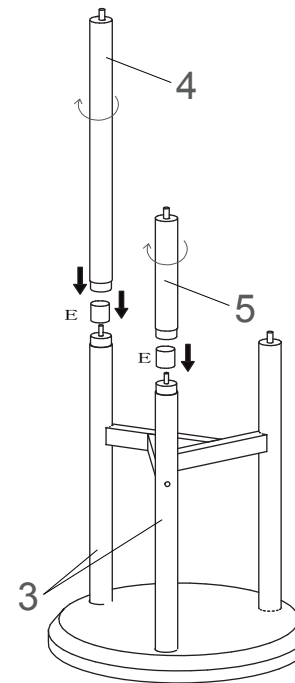

3. Connect parts (4)/(5) through sleeve E to lower support bar (3)

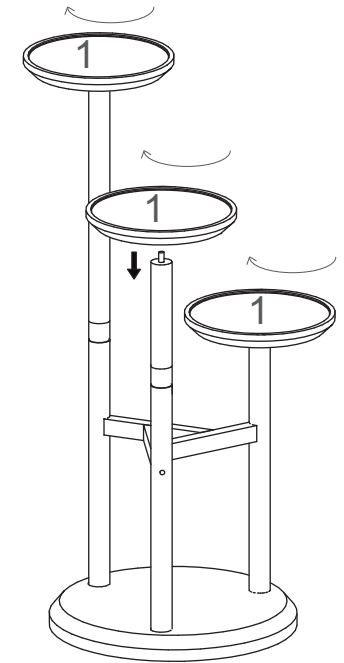

4. Connect the component (1) to the support bar.