

15 min	x1	x2

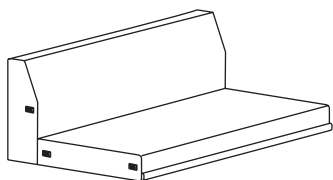

**A x1**

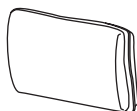
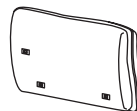

**B x1**



**C x1**



**D x2**

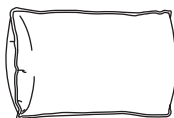

**E x2**



**F x4**



**G x1**



**H x6**  
M8



**I x6**  
M8

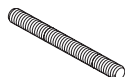

**J x6**  
M8x80

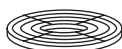

**K x4**



**L x4**

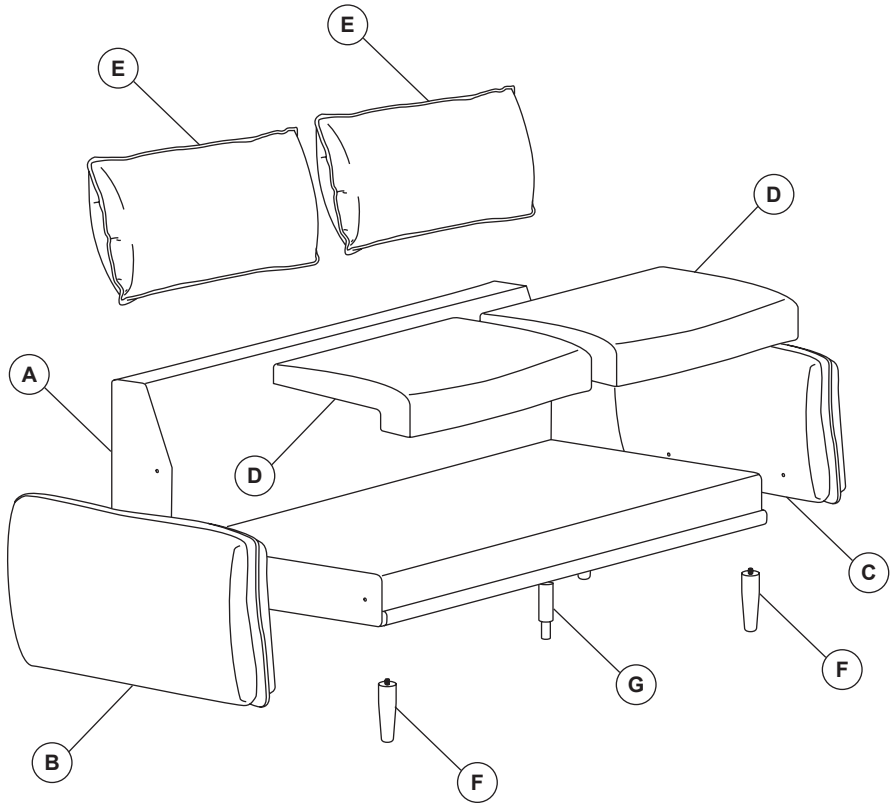

1

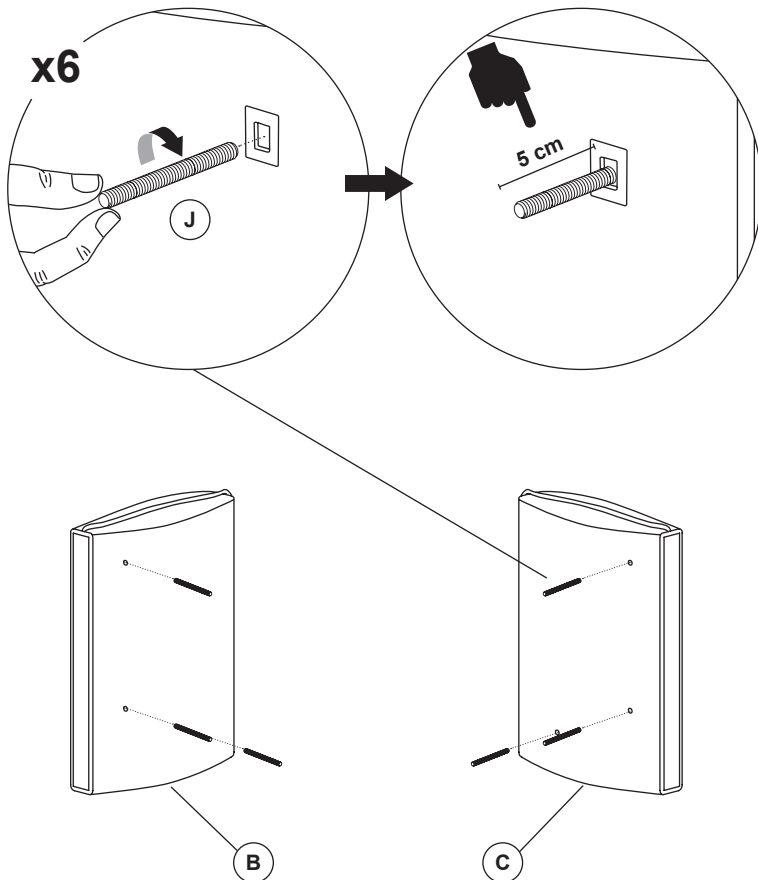

2

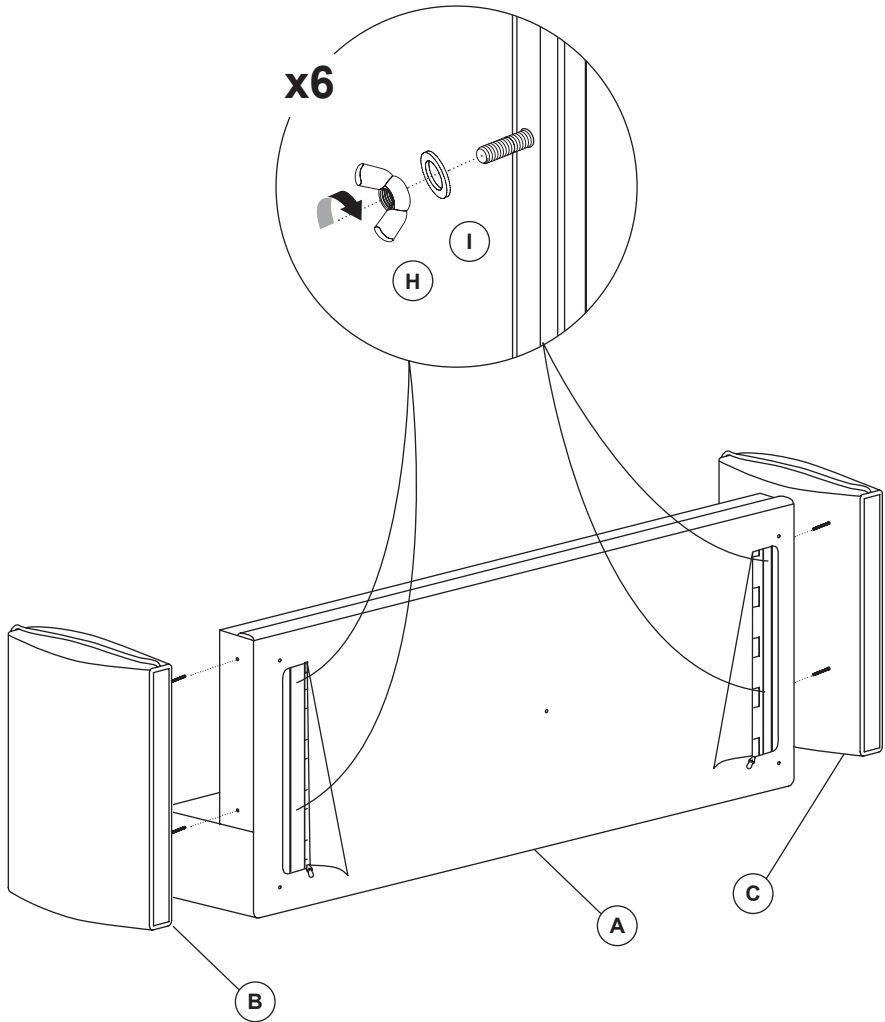

3

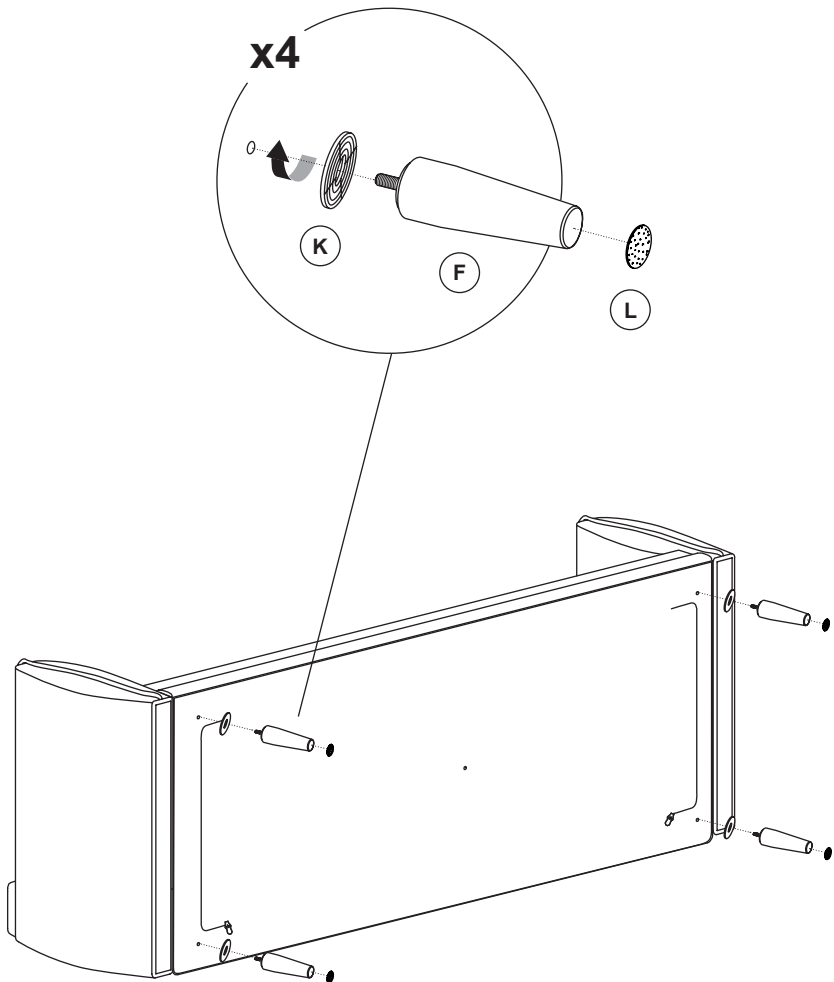

4

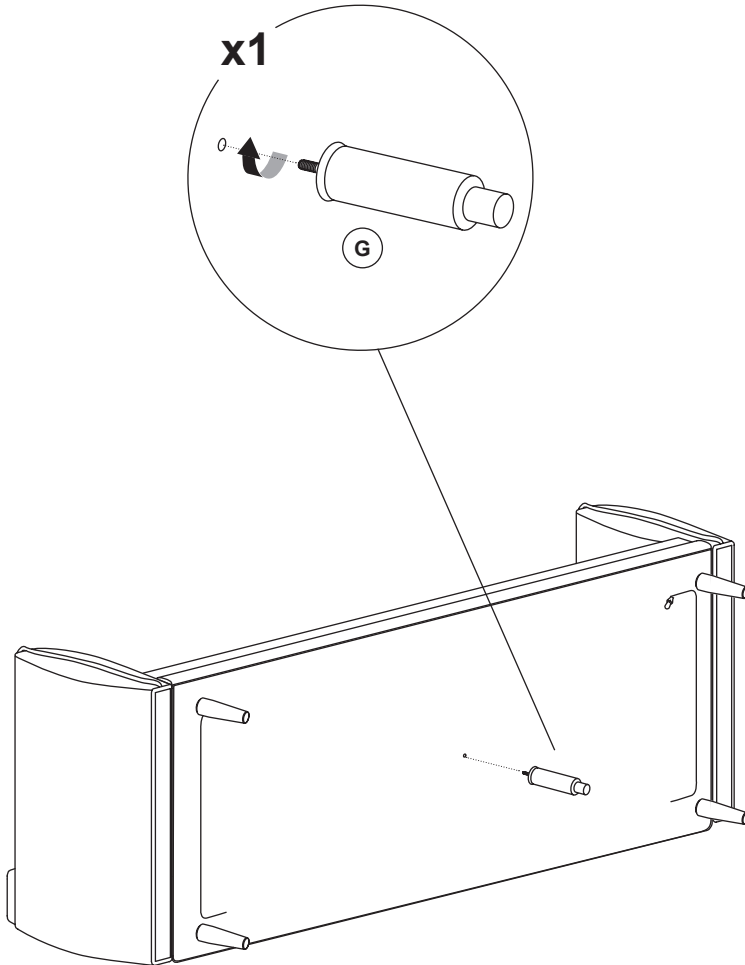



5

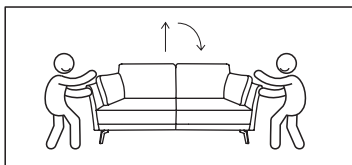
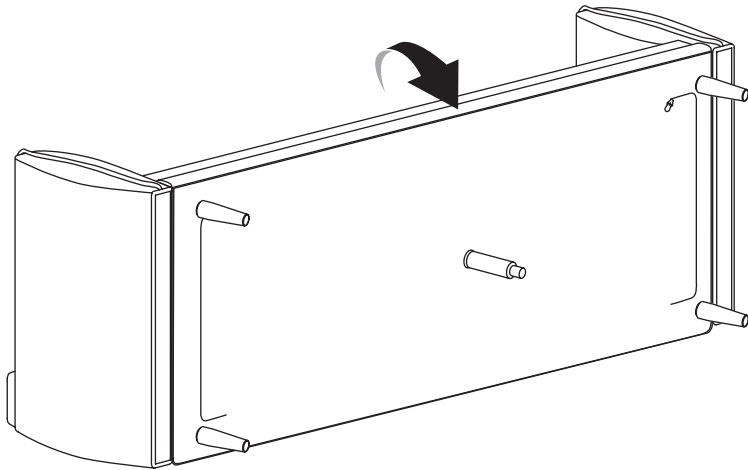

6

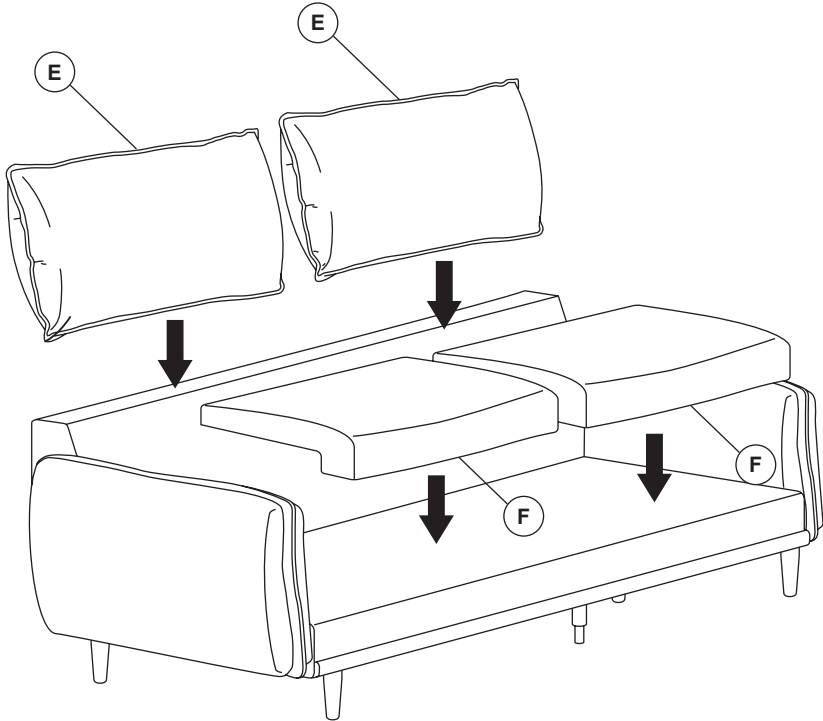

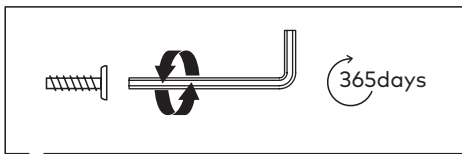
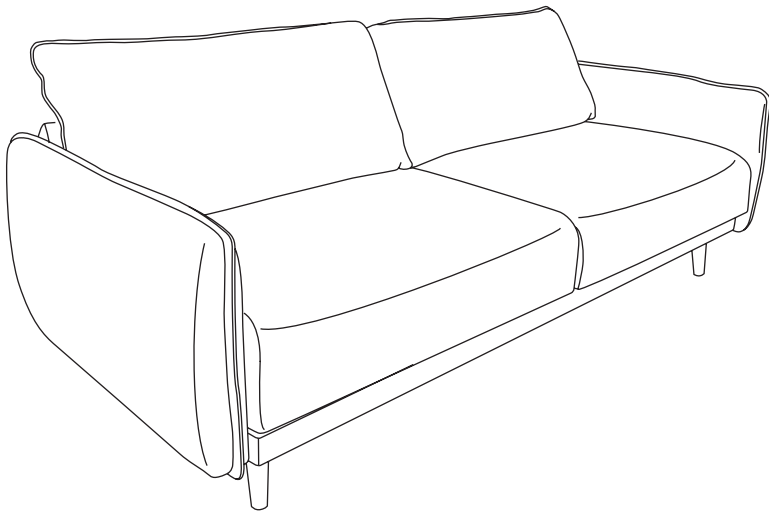



**THAT'S ALL FOLKS!**

Share your style!

**#KaveHome**

